



Advanced Products for Robotics and Automation

## PRODUCTS AND CAPABILITIES



## CGI STATE OF THE ART FACILITY

---



3400 Arrowhead Drive  
Carson City, NV 89706  
Toll Free: 1.800.568.4327  
[WWW.CGIMOTION.COM](http://WWW.CGIMOTION.COM)



**bsi.**

ADVANCED PRODUCTS FOR ROBOTICS AND AUTOMATION



## ABOUT CGI, INC.

Since 1967, CGI has consistently been providing for its customers exceptional craftsmanship and outstanding customer service. This unwavering commitment is what makes CGI the reliable choice for precision components and sub-assemblies.

Our capabilities in precision manufacturing feature a careful blend of cutting edge technology and world-renowned reliability.

**We've earned our superb reputation for partnering with our customers, bringing comprehensive technical knowledge, manufacturing expertise, high quality, and a "can-do" attitude to each unique application.**

Yet, perhaps most important is our commitment to providing your design and engineering team with a seamless connection to our manufacturing capabilities. We are able to provide our customers with an engineering team that is talented, knowledgeable and eager to help. We can turn-key your concept from the prototype stage all the way through to full production. With CGI you can count on us to provide the highest levels of manufacturing excellence and expertise while delivering it with the customer service you deserve. Our goal is to be the most trusted and reliable partner in your supply chain.

CGI continues in its commitment to provide the latest technology with innovative new products while consistently investing in state-of-the-art manufacturing, inspection, and assembly equipment. Our vertically integrated manufacturing facility is broad in its capabilities and features high end machinery aimed at providing excellent quality and rapid turnaround.

**CGI is your fully capable supply chain partner from prototype to product launch and life cycle support.** CGI's Engineering, Manufacturing and Quality departments employ the latest systems available, such as Solidworks with FE analysis, AutoCad, CAD/CAM, Infor Visual Enterprise with ERP system. We implement Kisoft gear and bearing software in every design application. We continually strive to improve your standard products as well as minimize the time from preliminary design to final design approval ready for production.



## CUSTOMER DRIVEN INNOVATION

At CGI we serve a wide array of industries including medical, robotics, aerospace, defense, semi-conductor, industrial automation, motion control, and many others. Our core business is manufacturing precision motion control solutions. CGI's diverse customer base and wide range of applications have earned us a reputation for quality, reliability, and flexibility.

One of the distinct competitive advantages we are able to provide our customers is an engineering team that is knowledgeable and easy to work with. You will enjoy a winning attitude that will take your ideas and collaborate with your team to develop them into finished products.

**CGI is certified to ISO9001 and ISO13485 quality management systems. In addition, we are FDA and AS9100 compliant. Our unique quality control environment is weaved into the fabric of our manufacturing facility.**

We work daily with customers who demand both precision and rapid turnarounds. CGI has always been willing to go above and beyond to meet these needs.

# PRODUCTS & SERVICES

From Prototype to Production CGI enables design excellence across a wide range of industrial applications. We thrive on customer driven innovation. We are your design and manufacturing partner helping to differentiate your product or innovation. Our team of problem solving engineers and product managers can bring your application to market on time and under budget. Whether it's an improvement on a current design or groundbreaking new designs, CGI has the know-how and team to enable design excellence.



## ADVANCED PRODUCTS

- Precision Gears
- Precision Gearboxes
- Precision Machined Components
- Precision Bearings (All Types)
- Mechanical Assemblies
- Electro-Mechanical Assemblies
- Customized Components All Types
- Contract Manufacturing - Assemblies

## FOR ROBOTICS AND AUTOMATION

## PROUDLY MADE IN AMERICA



CGI manufactures gears, gear boxes, precision machined components and sub-assemblies for custom applications. Our capabilities feature a careful blend of cutting edge technology and renowned reliability.



## ADVANCED PRODUCTS

### Assemblies, Gears, Bearings

CGI applies design sophistication using precision gearbox designs. Our advanced products are fabricated to meet customer design expectations or designed by CGI engineers to meet our customers' requirements. We implement our in-house manufacturing of precision individual components as well as assembly and testing to meet customers' requirements.

- Complex Machined Components
- Mechanical Assemblies
- Electro-Mechanical Assemblies
  - ESD Procedures and ESD Compliant Workbenches
- Assembly and Testing of Assemblies
- BOM: Multi-item component lists
- Functional Testing: Customer Specified Parameters
- Ball Bearings (Exotic, Specially Modified Customs)



FDA COMPLIANT, FOOD GRADE (CODE 4-204.15)  
WASH DOWN GEARBOX ASSEMBLIES



# ELECTRO-MECHANICAL ASSEMBLIES

CGI incorporates program management strategies to your entire assembly.

- Final Assembly Test and Pack (FATP)
- BOM management / Contract manufacturing
- Supplier Management
- Incoming Component Inspection
- Lot Number Control / Traceability
- Manufacturing Process Documentation created and controlled
- Assembly performed in environmentally controlled room and food restricted facility
- Testing may be performed upon completion of Electro-Mechanical Assembly in our Test Lab
- Complete Final Inspection performed
- Environmentally controlled quality inspection and metrology lab



MEDICAL



LABORATORY



ROBOTICS

# MECHANICAL ASSEMBLIES

At CGI, we provide you with a single-source solution that saves time and cost. **Eliminate purchase order processing, supplier management, inventory management, incoming inspection, BOM assembly staging, and takt time.**

- Turn-key Contract Manufacturing
- Manage your Sub-Assembly BOM
- Manage Supply Chain
- Manage Quality by Component / Top Assembly
- Assemble, test, and package for your production line or customer
- Careful Label control and documentation for each Component and Assembly.
- Complete Traceability is controlled and stored securely in multiple locations electronically for 10+ years





# FOCUS INDUSTRIES

- Medical Devices
- Medical Robotics
- Aerospace
- Defense
- Hi-Tech Robotics
- Semi-Conductor
- Automotive
- Industrial
- Packaging
- Automation
- UAV Autonomous Vehicles





# PRECISION GEARBOXES, GEARS & MACHINED COMPONENTS

Our team of highly skilled and diverse professionals at CGI, is committed to listening to your needs and delivering the value you deserve. We know that your application demands quality products designed right, on-time and within budget.

From specialized gear applications to precision servo gearboxes our reputation is defined every time a gearbox is integrated.



*AGMA has helped to set national gearing standards since 1916. The association also serves the focal point within the United States for the development of ISO gearing standards.*

*AGMA standards address nearly all the critical gearing topics, from load capacity and lubrication to accuracy and inspection.*



## PRECISION GEARS

### GEAR TYPES

- Anti-Backlash Gears
- Bevel Gears
- Helical Gears
- Internal Gears
- Lead Screws
- Metal Gears
- Pinion Gears
- Plastic Gears
- Rack gears
- Ring Gears
- Splines
- Spur Gears
- Worms



# PRECISION MACHINED COMPONENTS

## • PRECISION MACHINING

- Multi-tasking machines (multiple spindle, multiple turret)
- CNC Gear Fabrication
- Swiss Type Multi-tasking Machines
- CNC Lathe Machining
- CNC Vertical Milling
- CNC Horizontal Milling with Multi-Pallet Robots
- CNC 5-Axis Milling
- CNC Swiss Turning Machines
- CNC Cylindrical Grinding
- Wire EDM
- Honing

## • LIGHTS OUT MANUFACTURING FOR EFFICIENCY

## • MULTI-UP PALLETIZED MANUFACTURING FOR REDUCED SET-UPS

## • PRECISION GEAR FABRICATION

- Gear Hobbing
- Gear Shaping
- Bevel Gear Cutting
- Internal Gear Broaching (internal and external)

## • PRECISION FIXTURES (DEVELOPED IN-HOUSE)

## • CMM INSPECTION PROBES FOR PART IDENTIFICATION

## • IQ, OQ, PQ ARE STANDARD PRACTICES



PL Series: Prime Planetary Gearboxes



RC/DC Series: Prime Planetary Right Angle Gearboxes



VP Series: Victory Planetary Gearboxes

## PRECISION GEAR BOXES

## GEARBOXES

- Ultra Grade Gearboxes
- Mid Grade Gearboxes
- Instrument Grade Gearboxes
- Inline Gearboxes
- Right Angle Gearboxes
- Custom Gearboxes
- Offset Gear Motors
- Gear Motors
- Low Backlash Gearboxes
- Spur Gearboxes

**RATIOS: 1:1 to 10,000 :1**

**INPUT MOTOR SPEED: Up to 200,000 RPM**



Mechanical Assembly Area

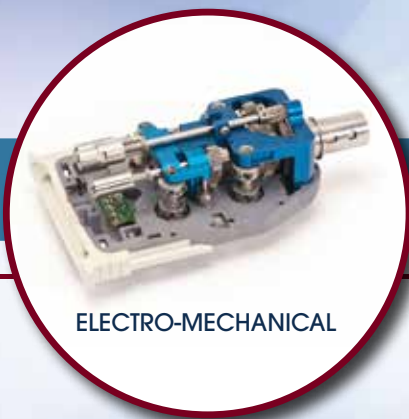

ELECTRO-MECHANICAL



MECHANICAL  
ASSEMBLY DEFENSE

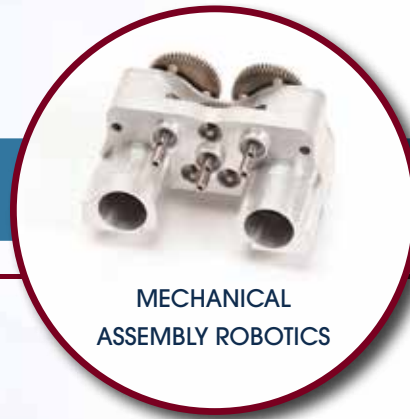

MECHANICAL  
ASSEMBLY ROBOTICS





Gear Misalignment

Gear Tooth Scuffing

## GEARS AND GEAR BOXES

- Failure Analysis Reports Available
- Metallurgical Analysis
- Dimensionally Checked
- Rotational Tests
- Noise Tests
- Torque Tests
- Frictional Tests
- AGMA / ISO verification analysis
- Bearing analysis / Preload Tests
- Tolerance verification of mating components
- Backlash
- Pitting, cracks, shear and fatigue

# CGI – FAILURE ANALYSIS: ROLLING ELEMENT BEARINGS

## BALL BEARINGS

- Failure Analysis Reports Available
- Metallurgical Analysis
- Dimensional testing
- Noise testing
- Vibration testing
- Roundness testing
- Component analysis
- Mating component inspection
- Bearing assembly testing
- Brinelling inspection
- Raceway Inspection
- Cracking of components
- Lubrication fill and type
- Cage design and integrity
- Corrosion analysis
- Electrical arcing
- Spalling detection
- Scratches of components
- Excessive heat generation
- Chemical Contamination
- ABEC / ISO Verification



Catastrophic Cage Failure

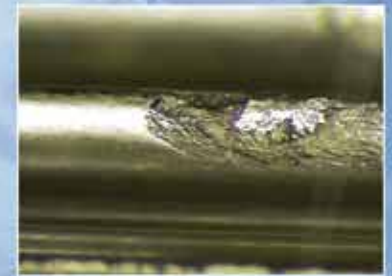

Macropitting/Spalling



Fretting Corrosion

## VERTICALLY INTEGRATED SERVICES

We offer Training Services, Inventory Management, Top-down–Bottom-up complete Traceability and Testing validation services. Our Infor Visual Enterprise ERP system provides an integrated manufacturing system along with systematic, traceable and controlled processes.



3-D MODEL PRINTING

## SERVICES

### Testing/Validation Services:

- Process Flowchart
- Process Failure Modes Effects and Analysis (PFMEA) IQ, OQ, PQ
- Special Process Validations
- First Article Reports - FAIRs
- Process Capability Studies
- Collaborative Inspection Plan Development (Bubble Prints)
- Control Plans
- Statistical Process Control (SPC) Cpk, Output Data

### Failure Analysis Services

### Rapid Prototype and 3D Printer Services, On-Site

### Training Services:

- Gear Seminars for Engineering Teams
- Small or Large Groups
- Located at CGI's Headquarters or Your Site
- Training Webinars

### BOM / Inventory Management

- Kanban/Inventory Management programs
- Kitting : Assembly Floor ready
- Inventory Management Solutions including Kanban and Blanket Purchase Order
- Sourcing Services integrated into CGI's robust Quality System

### Specialty Processes

- Platings, Coatings, Lubrications
- Gears, Bearings, Components

### On Shore and Off Shore Sourcing







Electro-Mechanical Assembly Area

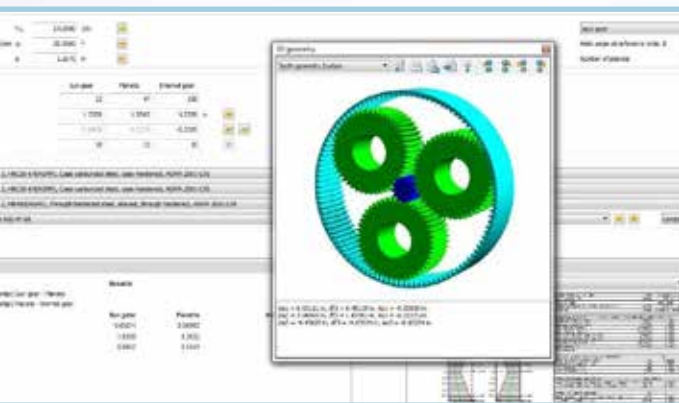
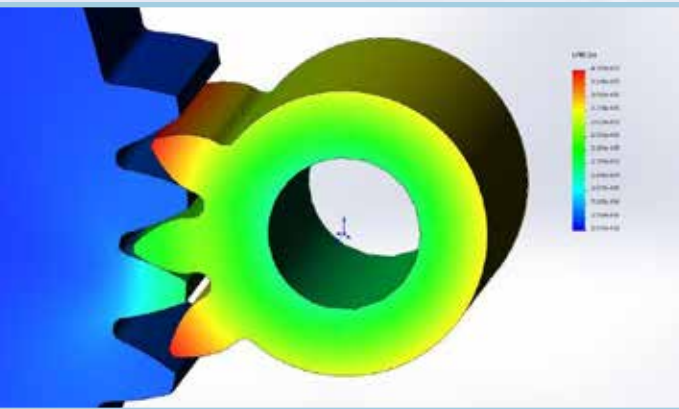

## DESIGN **ENGINEERING**

Our design engineering groups utilize the latest software & technology.



### Design Engineering Specializing in:

- Individual Gear Design
- Gear Systems / Gearbox Analysis
- Customized Gearbox Design
- Precision Machined Component Design
- Design Support for Advanced Devices and Systems
- Ball Bearing Applications
- 3-D CAD Modeling
- Direct Customer Support for Design Applications
- Finite Element Analysis for Design Reliability
- Design for Manufacturing (DFM)
- Solid Model Formats (IGES • STEP • DWG • DXF • STL • ProE • PARA Solid)

**LET CGI ENGINEERS BE AN EXTENSION OF YOUR TEAM**

*SOLIDWORKS is a solid modeling CAD (computer-aided design) software that is currently used by over 2 million engineers and designers at more than 165,000 companies worldwide. SOLIDWORKS Simulation provides core simulation tools to test your designs and make the decisions to improve quality. KISSsoft serves as a high-quality tool for sizing machine elements, reviewing calculations, determining component strength, and documenting safety factors and product life parameters.*





PRODUCTION ROBOTIC:  
MULTI-UP PRECISION FIXTURES

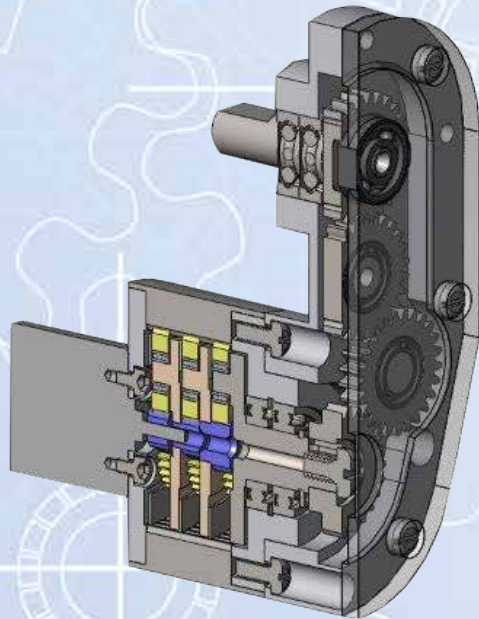

MEDICAL DEVICE PDR CONCEPT

## MANUFACTURING ENGINEERING SUPPORT

- Design for Manufacturability - DFM
- Fixturing Design and Fabrication
- Prototyping Support 3-D Model Printing on-site
- Process controls designed and implemented
- Process development for Assembly and Testing of Motion Control Assemblies for Advanced Devices and Systems
- Complete Test Device, Design & Development
- Minitab Statistical Analysis tools
- Computer Aided Machining (CAM)
- Six Sigma black belt expertise

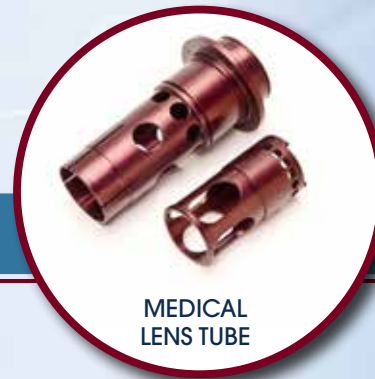

MEDICAL  
LENS TUBE



OFFSET SPUR  
GEAR MOTOR

# VERTICALLY INTEGRATED FLOW PROCESSES





# COMPLETE DOCUMENTATION AND TRACEABILITY



COMPLETE TOP-DOWN-BOTTOM-UP TRACEABILITY

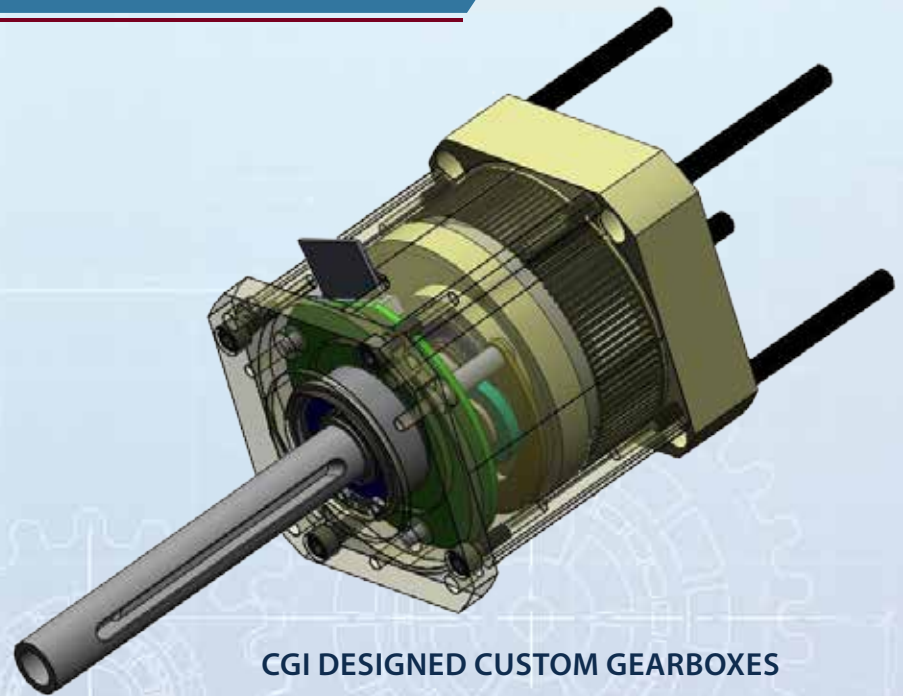

CGI DESIGNED CUSTOM GEARBOXES

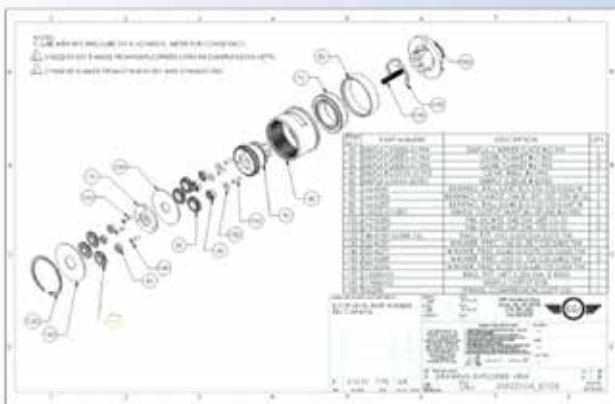

TOP ASSEMBLY, EXPLODED VIEW



MANUFACTURING/PROCESS INSTRUCTIONS

## Quality Equipment: Highly Qualified Inspection Department

- Zeiss Contura Coordinate Measuring Machine (CMM)
- Brown and Sharpe Coordinate Measuring Machine (CMM)
- PECO Next Dimension 300 Gear Analyzer
- Micro-Vu Vertex Vision System
- Starrett Optical Comparators with Digital Readout
- TESA Scanner
- PECO Dual Flank Test Roll Checker
- Micro Check Dual Flank Test Roll Checkers
- Vari-Roll Dual Flank Test Roll Checkers
- Toolmakers Microscope with Digital Readout
- Inspection Xpert software for First Article Reports

## FDA AND AS9100 COMPLIANT

Verification and Validation procedures are applied to meet and document defined processes and specifications. IQ, OQ, PQ processes are implemented and provided to customers as necessary.

SPC utilizes Minitab software for analysis. Extensive Hi-Tech state of the art Inspection Equipment is utilized and maintained (see equipment list)

**ISO 9001 Certified**

**ISO 13485 Certified**





# VERTICALLY INTEGRATED CAPABILITIES & ADVANCED PRODUCTS

## CAPABILITIES

- Gear Manufacturing
- Gearbox Manufacturing and Complete Assembly
- Assembly of Small to Large multi-items Component lists
- Complex Machined Components
- Testing of gearheads
- Mechanical Testing
- Electro-Mechanical Assemblies
- Specialty Fixturing Manufactured In-House to accommodate tight tolerance components
- Complete Assembly and Testing for Large BOM Contract Manufacturing
- Heat Treating
- Passivation
- Functional Testing
- FATP (Partner with OEMS)
- DHR Offered (Device History Register)
- Wire Type (EDM)
- Laser Welding (Rofin Select)
- Broaching of internal gears from small to large
- Multi-up manufacturing for reduced set-ups manufacturing efficiency

**RAPTOR EP • PREDATOR • RAPTOR  
PLANETARY GEARBOXES**



# MANUFACTURING CAPABILITIES

## MANUFACTURING

- **Precision Gear Fabrication (to AGMA 12+) / ISO 5 Quality**
  - Complete Gear manufacturing work cells
  - CNC Gear Hobbing, High Efficiency equipment
  - Gear Hobbing
  - Bevel Gear Cutting
  - Internal Gear Broaching
  - CNC Gear Hobbing
  - Short runs; Quick-Turn protos
  - High Volume Production runs
  - Over 70 Hobbing Machines
- **Specialty Fixturing manufactured in-house to accommodate tight tolerance components**

- **Complete Assembly and Testing**
- **Large BOM Contract Manufacturing**
- **Testing of various functions, (application specific)**
- **Precision Machining**
  - Multi-tasking Machining (multiple spindle, multiple turret)
  - Swiss Type Multi-tasking Machines (to .0001 in.)
  - CNC Lathe Machining (to .0003 in.)
  - CNC Vertical Milling (to .0002 in.)
  - CNC Horizontal Milling with Multi-Pallet Robots
  - CNC 5-Axis Milling (to .0002 in.)
  - Multi-Pallet Milling with Robots
  - CNC Swiss Type Turning (to .000050 in. or .0001 in. Total)
  - General Lathe Machining (to .0003 in.)
  - Large O.D. Lathe Turning
  - Laser Welding
  - Honing
  - Heat Treating
  - Passivation
  - Broaching of Internal Large to Small Gearing
  - Lights out manufacturing for efficiency
  - Multi-up Manufacturing for reduced set-ups
  - Multi-Pallet Robotic Hi-Volume Milling, lights-out
  - Specialty coatings / platings
  - Deburr Stations (Tumblers and Shakers)





# SUPPLIER MANAGEMENT PROCESS

## SUPPLYCHAIN

- Supplier Audits Performed Routinely
- Supplier Qualification/Approval to become a “CGI Approved Supplier”
- Dedicated Audit Forms Recorded and Stored
- On-Site Audits at Supplier manufacturing sites
- Supplier Scorecards
- RMA and SCAR tracking weekly / monthly
- What do we require from suppliers?
  - Lot number traceability
  - Raw Material Certifications
  - Manufacturers Certifications
  - SPC data if component is manufactured
  - First Article Inspection Report: FAIR data
  - Certifications of Compliance from Outside Process suppliers via CGI suppliers
    - Raw material / Dimensional compliance
  - Plating / Coating / Lubrication



**PM SERIES:  
PRIMETRIC PLANETARY GEARBOXES**

**KITTING & ASSEMBLY PLANNING**



**INVENTORY STORES BY BIN LOCATION**



# MATERIALS

## EXOTIC AND STANDARD MATERIALS LIST

### Stainless Steels (all)

- 300 Series all types
- 400 Series all types
- 17-4 ph
- 13-8 ph

### Carbon Steels

### Chromoly Steel

### Copper Alloys (Brass and Bronze)

### Aluminum all types

### Ceramics

### Exotic Metal Materials

- Titanium
- Nitronic all types
- Inconel
- Stellite
- M-50
- BG42
- Tungsten
- Waspaloy
- Hasteloy
- Cobalt

### Exotic Plastics all types (Other non-metallics)

- PEEK
- PTFE
- Nylon
- Acetal
- Polycarbonate
- Ultem
- Polyurethane
- Rubber
- Polyimide / amide
- ABS
- Phenolic
- Radel



EXOTIC METALS



EXOTIC PLASTICS



## WORLDWIDE CUSTOMER LOCATIONS



ISO QUALITY MANAGEMENT SYSTEMS: ISO 9001 • ISO 13485 • AS9100 • ITAR  
SIX SIGMA AND LEAN PRACTICES ARE EMBRACED DAILY WITHIN THE CULTURE

FOLLOW US ON



3400 Arrowhead Drive, Carson City, NV 89706

Toll Free: 1.800.568.4327 • Ph: 1.775.882.3422 • Fx: 1.775.882.9599

VISIT US AT [WWW.CGIMOTION.COM](http://WWW.CGIMOTION.COM)





Inc.

Advanced Products for Robotics and Automation

3400 Arrowhead Drive, Carson City, NV 89706

Toll Free: 1.800.568.4327 • Ph: 1.775.882.3422 • Fx: 1.775.882.9599

[WWW.CGIMOTION.COM](http://WWW.CGIMOTION.COM)

ISO QUALITY MANAGEMENT SYSTEMS: ISO 9001 • ISO 13485 • AS9100 • ITAR

SIX SIGMA AND LEAN PRACTICES  
ARE EMBRACED DAILY WITHIN THE CULTURE



**bsi.**